



# Darnaw1 User Manual

Issue – 1.00

## **Kit Contents**

You should receive the following items with you Darnaw1 development kit:

1 - Darnaw1 Board.

## **Foreword**

**PLEASE READ THIS ENTIRE MANUAL BEFORE PLUGGING IN  
OR POWERING UP YOUR DARNAW1 BOARD.  
PLEASE TAKE SPECIAL NOTE OF THE WARNINGS WITHIN  
THIS MANUAL.**

## **Trademarks**

Coolrunner-II, Spartan, ISE, EDK, Webpack, Xilinx are the registered trademarks of Xilinx Inc, San Jose, California, US.

Darnaw1 is a trademark of Enterpoint Ltd.

## **Introduction**

Welcome to your Darnaw1 board. Darnaw1 is a highly featured Spartan™-3 FPGA module, in Pin Grid array (PGA) format, supporting a large number of unallocated I/O for user use.

The aim of this manual is to assist in using the main features of Darnaw1. Should this manual fail to explain a feature sufficiently then our support team can be reached by email on [support@enterpoint.co.uk](mailto:support@enterpoint.co.uk).

## Finding Your Way Around

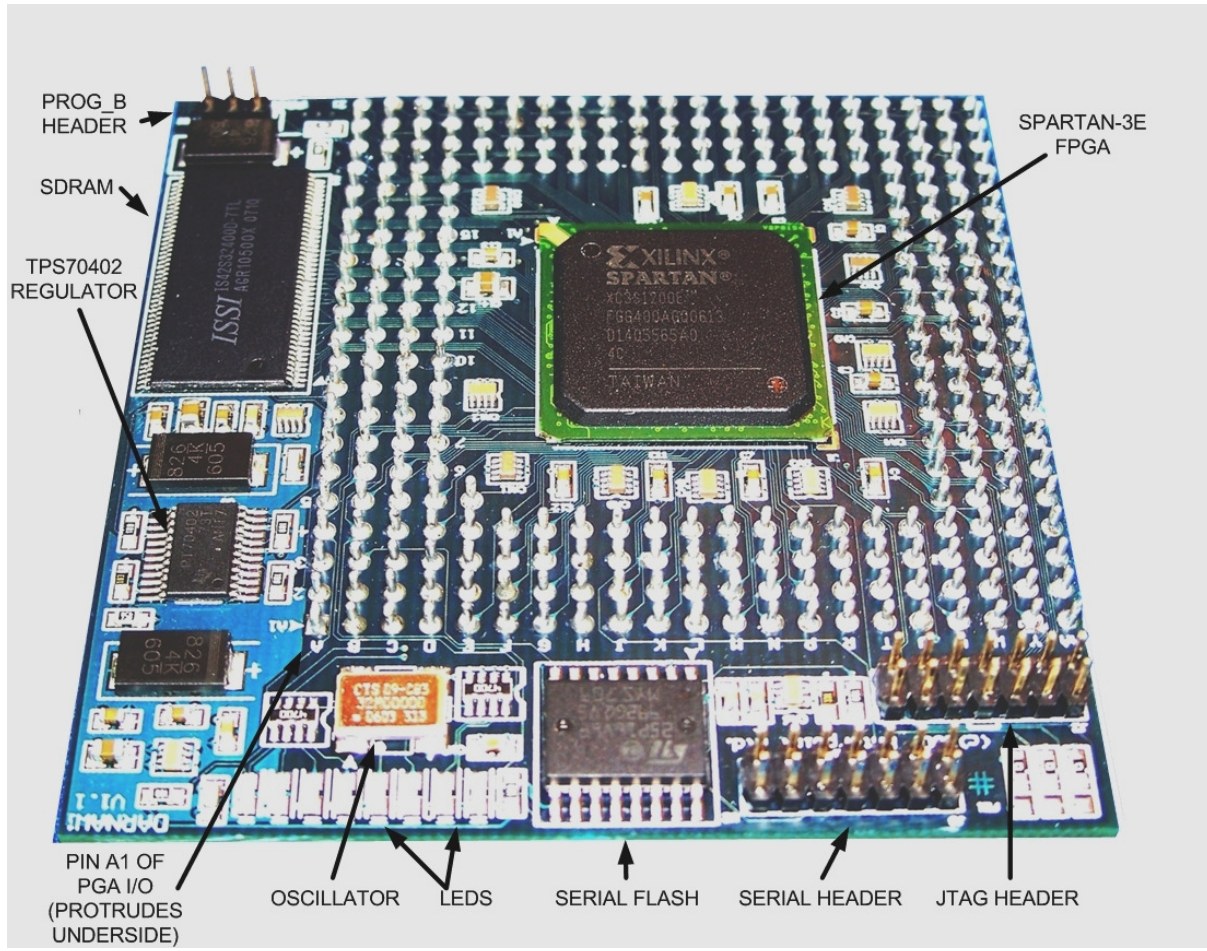

## **Getting Started**

- (1) Ensure that any vital data, contained within your host system, is backed up before attempting to use your Darnaw1 in the system.
- (2) Ensure that your host board for the Darnaw1 supplies bank voltages and main 3.3V power input to the Darnaw1.
- (3) Ensure that any signals that you are going input to Darnaw1 (a) do not exceed 3.5V (b) do not exceed 3.3V I/P power voltage + 0.5V.
- (4) Carefully plug, or solder, your Darnaw1 into the host board taking care not to bend pins of the Darnaw1. Sockets, including ZIF type, can be bought if you do not want to solder the module directly. Ensure the polarity of the Darnaw1 is correct when plugging in or soldering.

## Darnaw1 Features

### Power Inputs and Power Supplies

Darnaw1 uses a single 3.3V supply as power source and this is feed into the module on PGA pins A11-14 and B11-14. The associate DGND/0V is connected on PGA pins C11-14 and D11-14.

The on-board TPS70402 twin regulator chip derives from the input supply 1.22V and 2.5V which are used on the module for The Spartan<sup>TM</sup>-3E as core voltage and Vccaux supplies respectively.

The 1.22V supply is available for external use, monitoring, or for Bank Voltage use via PGA pins C1, B2 and A3. The total current capability (including internal use) of this power rail is 2 amps subject to thermal limitation.

The 2.5V supply is available for external use, monitoring, or for Bank Voltage use via PGA pins A1, A2 and B1. The total current capability (including internal use) of this power rail is 1 amp subject to thermal limitation.

Bank0 requires an input voltage to be fed in on PGA pins L18 and M18. You may use the main 3.3V as input or wire on your hosting board the 2.5V/1.22V output of the Darnaw1 to these pins. You can also wire any other voltage within normal operating range of the Spartan<sup>TM</sup>-3E.

Bank1 requires an input voltage to be fed in on PGA pins V10 and V11. You may use the main 3.3V as input or wire on your hosting board the 2.5V/1.22V output of the Darnaw1 to these pins. You can also wire any other voltage within normal operating range of the Spartan<sup>TM</sup>-3E.

Bank2 requires an input voltage to be fed in on PGA pins L4, M4 and N4. If you are using the Serial Flash on board it is recommended that 3.3V is input to this bank. The Serial Flash normally requires 2.7V (specification) or greater to operate but it may be possible to in practise to operate this bank at 2.5V if necessary. Operation of the Serial Flash at 2.5V is not guaranteed.

**WARNING – THE REGULATORS CAN GET VERY HOT IN NORMAL OPERATION ALONG WITH THE BOARDS THERMAL RELIEF. PLEASE DO NOT TOUCH OR PLACE HIGHLY FLAMABLE MATERIALS NEAR THESE DEVICES WHILST THE DARNAW1 MODULE IS IN OPERATION.**

## **Selecting the FPGA Bank (VCCIOX) voltages.**

Darnaw1 fixes the I/O voltage of FPGA bank 3 to 3.3V.

FPGA banks 0, 1 and 2 are supplied by the hosting board and can be anywhere in the normal Spartan<sup>™</sup>-3E operating range.

Please note the limitations of the Serial Flash (ST Microelectronics M25P16) is a minimum of 2.8V and it is on the Bank2 power supply. Failure to meet this may mean that the Darnaw1 FPGA does not configure.

## **Programming Darnaw1**

For programming and building your design you will need to download a copy of ISE Webpack™ form Xilinx™. You can obtain it here:

[http://www.xilinx.com/ise/logic\\_design\\_prod/webpack.htm](http://www.xilinx.com/ise/logic_design_prod/webpack.htm)

The programming of the FPGA and Serial Flash parts on Darnaw1 is achieved separate JTAG and Serial Flash interfaces. These interfaces appear on connectors J3 (Serial Flash) and J2 (JTAG). The interfaces also appear on PGA pins allowing programming via the hosting board. Signals are located as follows:

Serial Flash Programming	
Signal	PGA Pin
PROG_B	A9
SPI_SD_IN(FPGA-MOSI)	B4
SP_SD_OUT(FPGA-DIN)	B3
SPI_SCLK(FPGA-CCLK)	B6
SPI_CS_N(FPGA-CS0_B)	A5
JTAG Programming	
Signal	PGA Pin
TDI	Y21
TMS	Y20
TCK	AA20
TDO	AA21
Other Useful Signals	
Signal	PGA Pin
INIT_B	A4
DONE	N/A

Programming is carried out using our programming cable Prog2 or any Xilinx™ cable later than Parallel Cable IV and the tool IMPACT from the Xilinx™ ISE toolset.

The headers J2, J3 conform to the normal Xilinx standard pinout with the exception that Prog\_B signal is on the Serial Flash header. When a programming cable is plugged into the Serial Flash header Prog\_B is held at 0V/DGND placing the on-board Spartan™-3E FPGA into pre-configuration mode. This avoids drive conflicts of the FPGA against the programming cable. You must remove the programming cable from J3 to allow the FPGA to configure.

Header J4 also provides a manual method to hold Prog\_B at 0V/DGND by fitting a jumper over pins 1 and 2 of this header. Pin3 is provided as jumper store and fitting a jumper in pins 2 and 3 will have no effect.

The JTAG chain will report a single device XC3S1200E or XC3S1600E when INITIALISE CHAIN command is used within the tool ISE IMPACT. Direct JTAG programming is volatile and

the FPGA will lose its configuration every time the board power is cycled. From sustained use of FPGA design programming the design into the Serial Flash memory is recommended. Generation of suitable Serial Flash content files and control of the JTAG chain can be achieved using the XILINX ISE tool IMPACT.

The standard device in the Serial Flash position is the ST Microelectronics M25P16.

## **FPGA**

Darnaw1 supports Spartan™-3E devices in the FGG400 package. Standard builds of Darnaw1 use commercial grade devices but industrial grade parts can be fitted at extra cost. Currently either XC3S1200E or XC3S1600E devices are fitted as standard to the Darnaw1.

FPGA reference voltage pins are available for FPGA banks 0, 1, and 2 on the PGA pins. To use reference voltages the hosting board must connect all I/Os, that are used as Vref, in any given bank to the reference voltage required. The 1.22V output of the Darnaw1 can often be used as a reference voltage for 2.5V signalling systems.

Programming of the FPGA is supported by JTAG and from serial on-board Serial Flash devices.

## **Serial Flash**

Your Darnaw1 normally has a 16 MBit Serial Flash fitted. This is used to configure the Spartan-3E FPGA but the portion of this device unused can be used as code/data storage for embedded microprocessors like MicroBlaze™. Normally the M25P16 from ST Microelectronics is fitted in this position.

When a XC3S1200E FPGA is fitted 3,841,184 bits are used for configuration. When a XC3S1600E FPGA is fitted 5,969,696 bits are used for configuration.

As a build option we can fit M25P32 (32 MBit) and M25P64 (64 MBit) devices in this position and other suitable vendor devices to increase code storage capability.

## **LEDS**

Supplied on Darnaw1 there are 8 LEDS driven by the FPGA. LED1 cannot be driven by the FPGA but may be driven by the PGA pin on the net.

The LED1 is adjacent to Serial Flash and LEDs count in number away from the Serial Flash. LEDs are situated on IO pins as indicated below.

LED	LED1	LED2	LED3	LED4	LED5	LED6	LED7	LED8
PGA PIN	G1	G2	G3	G4	F1	F2	F3	F4
FPGA PIN	T10	Y9	W9	V9	Y8	W8	V2	Y7

## **OSCILLATOR**

A standard 7x5 oscillator is fitted. Usually a 32 MHz oscillator is fitted. We can do special values in this position at extra cost or for large volume runs.

## **SDRAM MEMORY**

Normally a 128 MBit SDRAM from Micron Technology or ISSI is fitted. This device is X32 organisation and operates from the 3.3V input supply.

The device is connected to Bank3 of the FPGA. The pin connections can be found in the Darnaw1 schematics linked off the Darnaw1 product page:

<http://www.enterpoint.co.uk/moelbryn/darnaw1.html>

## **Medical and Safety Critical Use**

Darnaw1 boards are not authorised for the use in, or use in the design of, medical or other safety critical systems without the express written person of the Board of Enterpoint. If such use is allowed the said use will be entirely the responsibility of the user. Enterpoint Ltd will accept no liability for any failure or defect of the Darnaw1 board, or its design, when it is used in any medical or safety critical application.

## **Warranty**

Darnaw1 comes with a 90 return to base warranty.

Other specialised warranty programs can be offered to users of multiple Enterpoint products. Please contact sales on [boardsales@enterpoint.co.uk](mailto:boardsales@enterpoint.co.uk) if you are interested in these types of warranty,

## **Support**

Enterpoint offers support during normal United Kingdom working hours 9.00am to 5.00pm. Please examine our Darnaw1 FAQ web page and the contents of this manual before raising a support query. We can be contacted as follows:

Telephone	- +44 (0) 1684 585262
Email	- <a href="mailto:support@enterpoint.co.uk">support@enterpoint.co.uk</a>